

# Single Phase Multifunction Energy Metering IC with SPI Interface



## SA9903B

### FEATURES

- Bidirectional active and reactive power/energy measurement
- RMS voltage and frequency measurement
- SPI communication bus
- Meets the IEC 61036 Specification requirements for Class 1 AC Watt hour meters
- Meets the IEC 61268 Specification requirements for Class 2 AC VAR hour meters
- Protected against ESD
- Total power consumption rating below 25mW
- Adaptable to different current sensor technologies
- Operates over a wide temperature range
- Precision on-chip voltage reference
- Measures AC inputs only

### DESCRIPTION

The SA9903B is a single phase bidirectional energy/power metering integrated circuit that has been designed to measure active and reactive energy, RMS mains voltage and mains frequency. The SA9903B has an integrated SPI serial interface for communication with a microcontroller. Measured values for active and reactive energy, the mains voltage and frequency are accessible through the SPI interface from 24 bit registers. The SA9903B active and reactive energy registers are capable of holding at least 52 seconds of accumulated energy at full load. A mains voltage zero crossover is available on the FMO output.

The SA9903B includes all the required functions for single phase power and energy measurement such as oversampling A/D converters for the voltage and current sense inputs, power calculation and energy integration. This innovative universal single phase power/energy metering integrated circuit is ideally suited for energy calculations in applications such as electricity dispensing systems, residential metering and factory energy metering and control.

The SA9903B integrated circuit is available in a 20 pin small outline (SOIC20) RoHS compliant package.

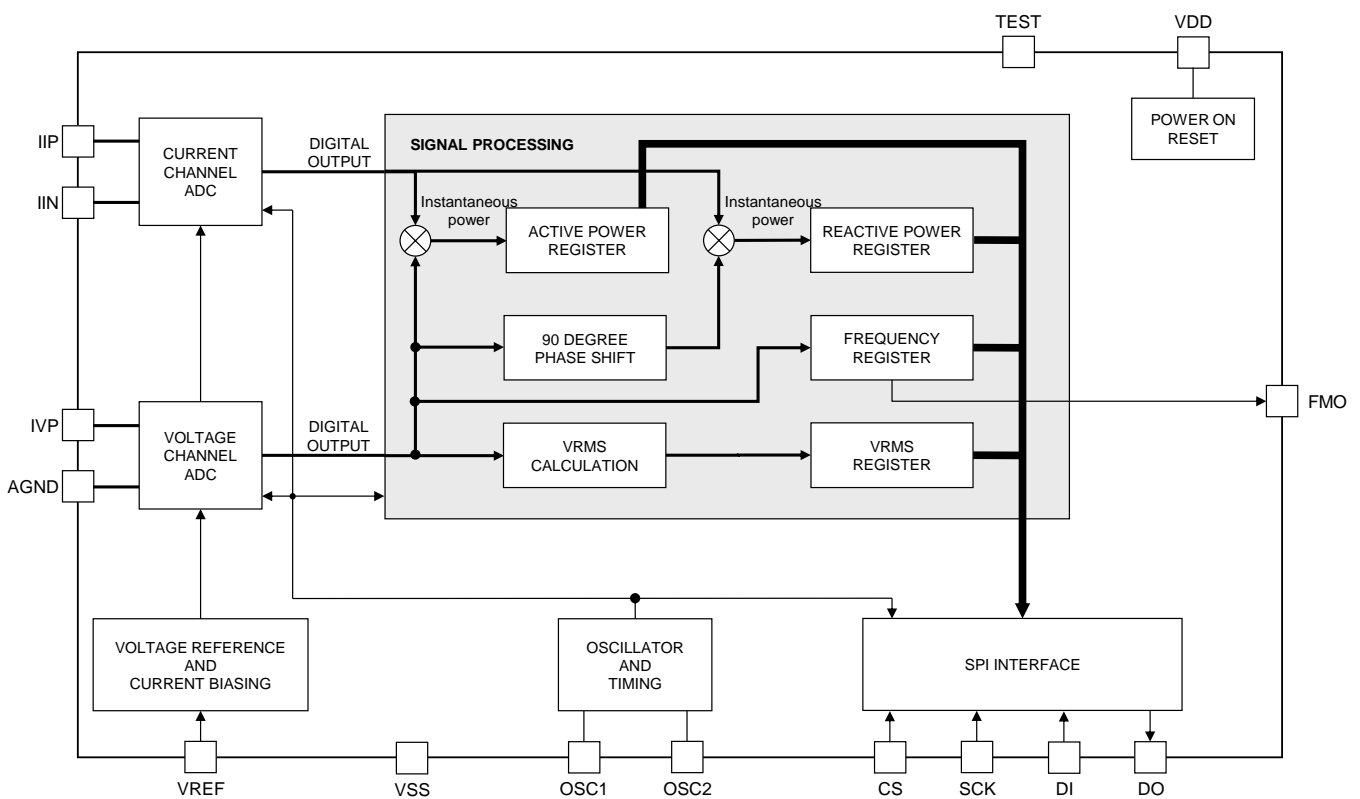

Figure 1: Block diagram

## ELECTRICAL CHARACTERISTICS

( $V_{DD} - V_{SS} = 5V \pm 10\%$ , over the temperature range  $-40^{\circ}C$  to  $+85^{\circ}C$ , unless otherwise specified. Refer to Figure 2 "Test circuit for electrical characteristics".)

Parameter	Symbol	Min	Typ	Max	Unit	Condition
<b>General</b>						
Supply Voltage: Positive	$V_{DD}$	2.25	2.5	2.75	V	With respect to AGND
Supply Voltage: Negative	$V_{SS}$	-2.75	-2.5	-2.25	V	With respect to AGND
Supply Current: Positive	$I_{DD}$		3.5	5.1	mA	
Supply Current: Negative	$I_{SS}$		-3.5	-5.1	mA	
<b>Analog Inputs</b>						
<b>Current Sensor Inputs (Differential)</b>						
Input Current Range	$I_{RIIP}, I_{RIIN}$	-25		25	$\mu A$	Peak value
Offset Voltage	$V_{OIIIP}, V_{OIIIN}$	-4		4	mV	With $R = 4.7k\Omega$ connected to AGND
<b>Voltage Sensor Inputs (Asymmetrical)</b>						
Input Current Range	$I_{RIVP}$	-25		25	$\mu A$	Peak value
Offset Voltage	$V_{OIVP}$	-4		4	mV	With $R = 4.7k\Omega$ connected to AGND
<b>Digital Inputs</b>						
SCK, CS, DI Input High Voltage	$V_{IH}$	$V_{DD}-1$			V	
Input Low Voltage	$V_{IL}$			$V_{SS}+1$	V	
SCK Maximum clock frequency	$f_{SCK}$			800	kHz	
Minimum clock low time	$t_{LO}$	0.6			$\mu s$	
Minimum clock high time	$t_{HI}$	0.6			$\mu s$	
<b>Digital Outputs</b>						
FMO, DO Output High Voltage	$V_{OH}$	$V_{DD}-1$			V	$I_{SOURCE} = 5mA$
Output Low Voltage	$V_{OL}$			$V_{SS}+1$	V	$I_{SINK} = 5mA$

During manufacturing, testing and shipment we take great care to protect our products against potential external environmental damage such as Electrostatic Discharge (ESD). Although our products have ESD protection circuitry, permanent damage may occur on products subjected to high-energy electrostatic discharges accumulated on the human body and/or test equipment that can discharge without detection. Therefore, proper ESD precautions are recommended to avoid performance degradation or loss of functionality during product handling.

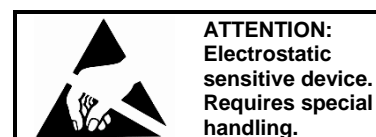

**ELECTRICAL CHARACTERISTICS (continued)**

( $V_{DD} - V_{SS} = 5V \pm 10\%$ , over the temperature range  $-40^{\circ}\text{C}$  to  $+85^{\circ}\text{C}$ , unless otherwise specified. Refer to Figure 2 "Test circuit for electrical characteristics".)

Parameter	Symbol	Min	Typ	Max	Unit	Condition
<b>On-chip Voltage Reference</b>						
Reference Voltage	$V_R$	1.15	1.20	1.25	V	
Reference Current	$-I_R$	47.9	50.0	52.1	$\mu\text{A}$	With $R = 24\text{k}\Omega$ connected to $V_{SS}$
Temperature Coefficient	$\text{TC}_R$		10	70	$\text{ppm}/^{\circ}\text{C}$	
<b>Oscillator</b>						
Recommended crystal	$f_{\text{OSC}}$		3.5795		MHz	TV colour burst crystal

**ABSOLUTE MAXIMUM RATINGS\***

Parameter	Symbol	Min	Max	Unit
Supply Voltage	$V_{DD} - V_{SS}$		6	V
Current on any Pin	$I_{\text{PIN}}$	-150	150	mA
Storage Temperature	$T_{\text{STG}}$	-60	+125	$^{\circ}\text{C}$
Specified Operating Temperature Range	$T_O$	-40	+85	$^{\circ}\text{C}$
Limit Range of Operating Temperature	$T_{\text{limit}}$	-40	+85	$^{\circ}\text{C}$

\*Stresses above those listed under "Absolute Maximum Ratings" may cause permanent damage to the device. This is a stress rating only. Functional operation of the device at these or any other condition above those indicated in the operational sections of this specification, is not implied. Exposure to Absolute Maximum Ratings for extended periods may affect device reliability.

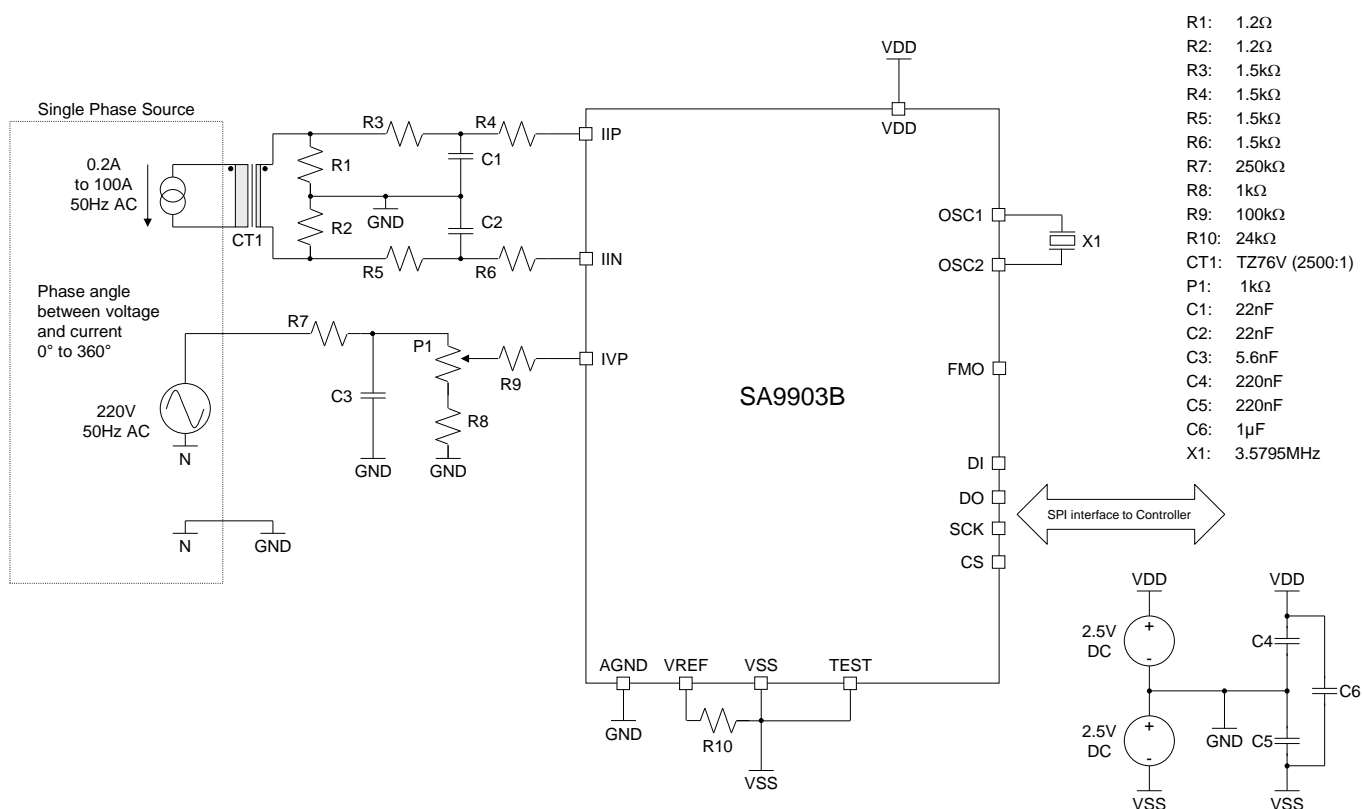

Figure 2: Test circuit for electrical characteristics

**PIN DESCRIPTION**

Designation	Pin No.	Description
AGND	20	Analog Ground. This is the reference pin for the current and voltage signal sensing networks. The supply voltage to this pin should be mid-way between V <sub>DD</sub> and V <sub>SS</sub> .
VDD	8	Positive Supply Voltage. The voltage to this pin should be +2.5V ± 10% with respect to AGND.
VSS	14	Negative Supply Voltage. The voltage to this pin should be -2.5V ± 10% with respect to AGND.
IVP	19	Analog Input for Voltage. The nominal current into the voltage sense input IVP should be set at 14μA <sub>RMS</sub> . The voltage sense input saturates at an input current of ±25μA peak.
IIP, IIN	2, 1	Analog Inputs for Current. The maximum current into the current sense inputs IIP/IIN should be set at 16μA <sub>RMS</sub> . The current sense inputs saturate at an input current of ±25μA peak.
VREF	3	This pin provides the connection for the reference current setting resistor. A 24kΩ resistor connected to V <sub>SS</sub> sets the optimum operating conditions.
OSC1, OSC2	11, 10	Connection for crystal
SCK	12	SPI Serial Clock input. This pin is used to strobe data in and out of the SA9903B
CS	18	SPI Chip Select input. This input pin enables the SPI interface. It is active high.
DI	17	SPI Data In input. Input data is accepted on this pin at the rising clock edge on SCK when CS is active.
DO	13	SPI Data Out output. Output data is strobed out on this pin at the rising clock edge on SCK when CS is active. DO is not driven when CS is inactive.
FMO	15	Voltage zero crossover. The F50 output generates a 50% duty cycle pulse on every rising edge of the mains voltage.
TEST	7	Manufacturers test pin, connect this pin to V <sub>SS</sub> for normal operation
NC	4, 5, 6, 9, 16	No connection, leave unconnected

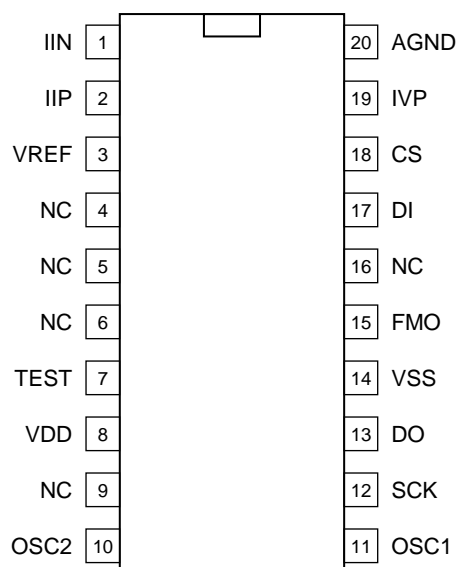

Figure 3: Pin connections

**ORDERING INFORMATION**

Part Number	Package
SA9903BSAR	SOIC20 (RoHS compliant)

## TERMINOLOGY

### Positive Energy

Positive energy is defined when the phase difference between the input signals IIP and IVP is less than 90 degrees (-90..90 degrees).

### Negative Energy

Negative energy is defined when the phase difference between the input signals IIP and IVP is greater than 90 degrees (90..270 degrees).

### Percentage Error\*

Percentage error is given by the following formula:

$$\%Error = \frac{Energy\ registered - True\ Energy}{True\ Energy} \times 100$$

NOTE: Since the true value cannot be determined, it is approximated by a value with a stated uncertainty that can be traced to standards agreed upon between manufacturer and user or to national standards.

### Rated Operating Conditions\*

Set of specified measuring ranges for performance characteristics and specified operating ranges for influence quantities, within which the variations or operating errors of a meter are specified and determined.

### Specified Measuring Range\*

Set of values of a measured quantity for which the error of a meter is intended to lie within specified limits.

### Specified Operating Range\*

A range of values of a single influence quantity, which forms a part of the rated operating conditions.

### Limit Range of Operation\*

Extreme conditions which an operating meter can withstand without damage and without degradation of its metrological characteristics when it is subsequently operated under its rated operating conditions.

### Maximum Rated Mains Current ( $I_{MAX}$ )

Maximum rated mains current is the specified maximum current flowing through the energy meter at rated operating conditions.

### Constant\*

Value expressing the relation between the active energy registered by the meter and the corresponding value of the test output. If this value is a number of pulses, the constant should be either pulses per kilowatt-hour (imp/kWh) or watt-hours per pulse (Wh/imp).

### Nominal Mains Voltage ( $V_{NOM}$ )

Nominal mains voltage ( $V_{NOM}$ ) is the voltage specified for the energy meter at rated operating conditions.

### Maximum Energy ( $F_{MAX}$ )

The maximum energy is defined as the energy registered on the active register of the SA9903B when  $14\mu A_{RMS}$  and  $16\mu A_{RMS}$  input current with zero phase shift are applied to the voltage and current inputs respectively. Both the voltage and current inputs saturate at an input current magnitude of  $25\mu A$ , or at  $17.68\mu A_{RMS}$  when using sine waves. The maximum input current on any channel is therefore defined to be  $16\mu A_{RMS}$ , which leaves about 10% headroom to the saturation point. An additional headroom of 15% is reserved on the voltage channel to account for mains voltage fluctuations. The nominal output frequency of 320000 counts per second is achieved under such conditions.

\* IEC 62052-11, 2003. Electricity Metering Equipment (AC) – General Requirements, Test and Test Conditions  
– Part 11: Metering Equipment

**PERFORMANCE GRAPHS**

Figure 4: Test circuit for performance graphs



Graph 1: Active Energy, Freq = 50Hz, VMains = VNOM, Temp = 25°C, VDD-VSS = 5.0V

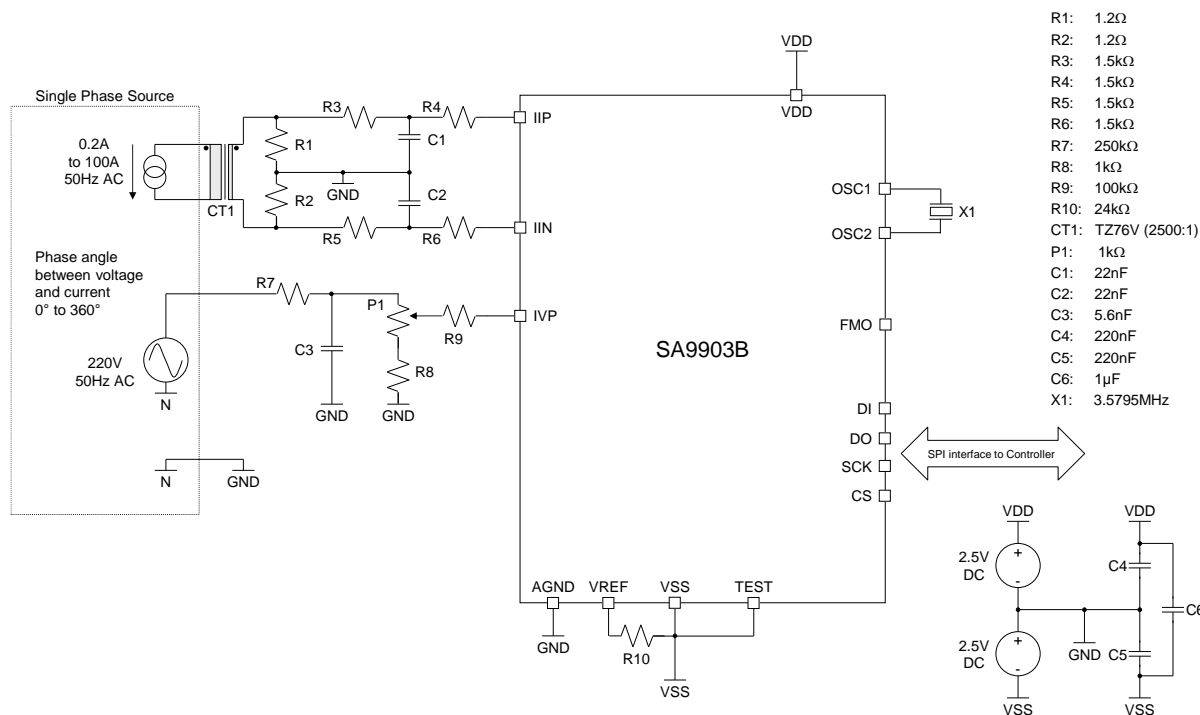
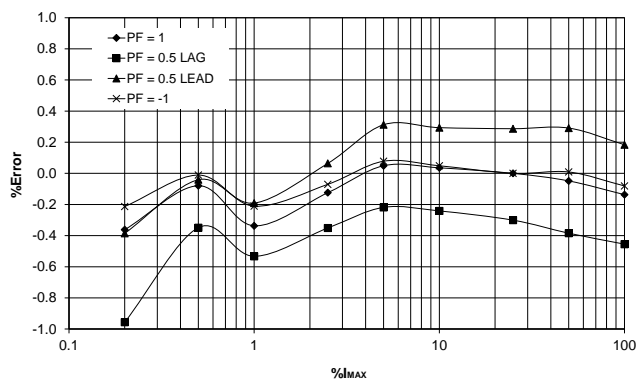
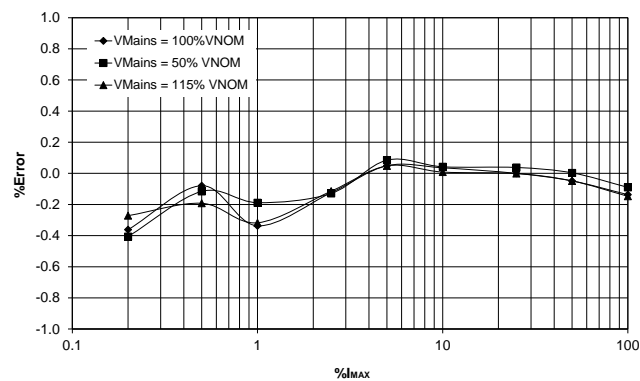

Graph 2: Active Energy, PF = 1, Freq = 50Hz, Temp = 25°C, VDD-VSS = 5.0V

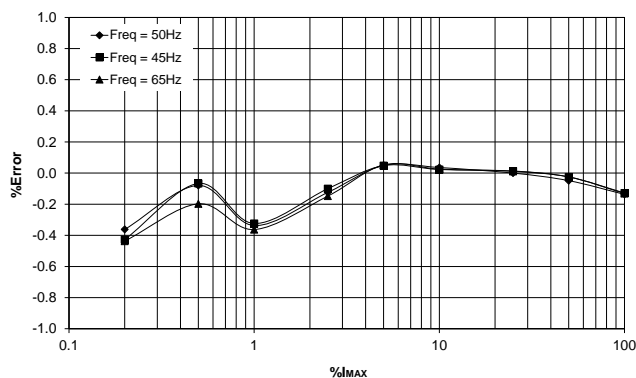

Graph 3: Active Energy, PF = 1, VMains = VNOM, Temp = 25°C, VDD-VSS = 5.0V

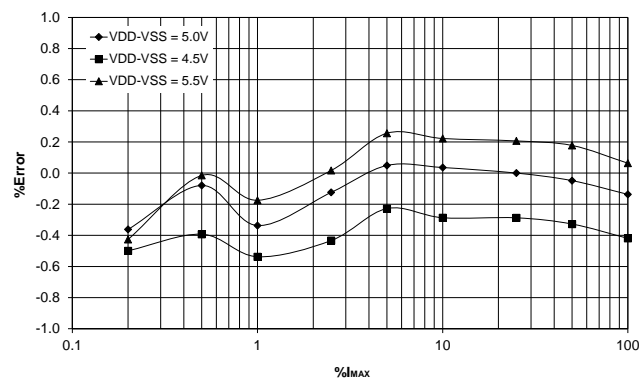

Graph 4: Active Energy, PF = 1, Freq = 50Hz, VMains = VNOM, Temp = 25°C



SA9903B

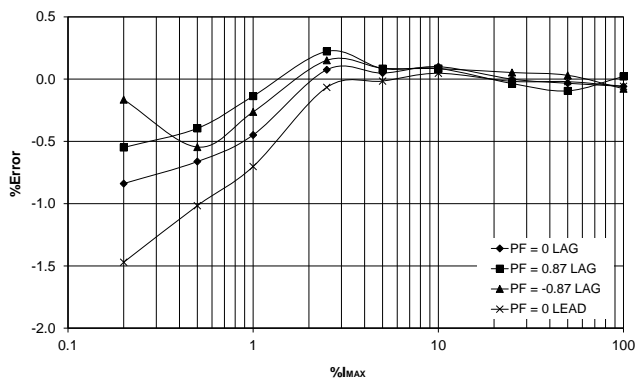

Graph 5: Reactive Energy, Freq = 50Hz, VMains = VNOM, Temp = 25°C, VDD-VSS = 5.0V

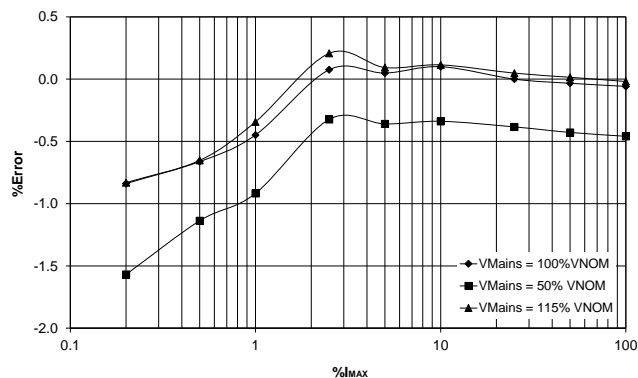

Graph 6: Reactive Energy, PF = 0 LAG, Freq = 50Hz, Temp = 25°C, VDD-VSS = 5.0V

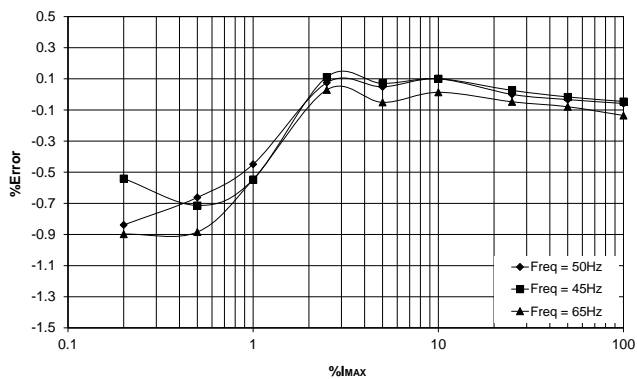

Graph 7: Reactive Energy, PF = 0 LAG, VMains = VNOM, Temp = 25°C, VDD-VSS = 5.0V

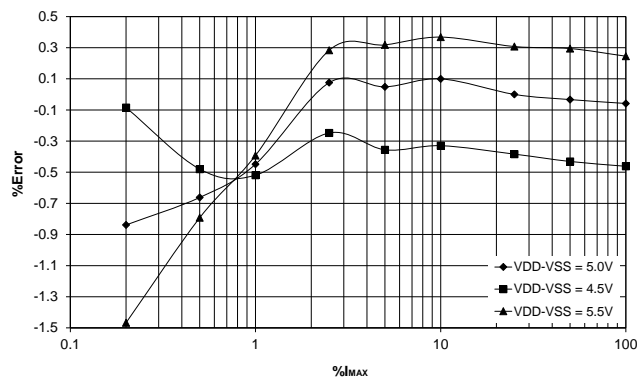

Graph 8: Reactive Energy, PF = 0 LAG, Freq = 50Hz, VMains = VNOM, Temp = 25°C

## FUNCTIONAL DESCRIPTION

The SA9903B is a CMOS mixed signal integrated circuit, which performs the measurement of active power, reactive power, RMS voltage and mains frequency. The integrated circuit includes all the required functions for single phase power and energy measurement such as oversampling A/D converters for the voltage and current sense inputs, power calculation and energy integration.

The SA9903B integrates instantaneous active and reactive power into 24 bit registers. RMS voltage and frequency are continuously measured and stored in the respective registers. The mains voltage zero crossover is available on the FMO output. The SPI interface of the SA9903B has a tri-state output that allows connection of more than one metering device on a single SPI bus.

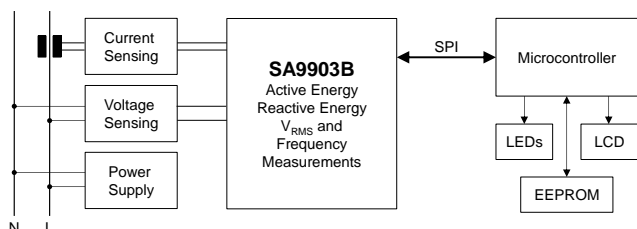

Figure 5: Typical architecture of an energy meter using the SA9903B

In the typical meter architecture, a microcontroller is used in conjunction with the SA9903B. In addition to communicating with the SA9903B the controller is used to read/write parameters to the EEPROM, output pulses for fast calibration and to display the consumed active and reactive power,  $V_{RMS}$  and mains frequency information. Other parameters such as  $I_{RMS}$ , phase angle etc. can be accurately calculated.

### Theory of Operation

The SA9903B includes all the required functions for single channel multifunction power and energy measurement. Identical AD converters sample the mains voltage and current input signals. The pair of digital signals, accurately representing the voltage and current inputs, is used to calculate active energy, reactive energy,  $V_{RMS}$  and the mains frequency. These quantities are stored in 24 bit registers that can be accessed via the SPI bus. The energy registers accumulate instantaneous energy.

For given voltage and current signals the instantaneous active power is calculated by:

$$p(t) = v(t) \times i(t)$$

$$p(t) = V_M \cos(\omega t + \theta) \times I_M \cos(\omega t + \psi)$$

Let  $\phi = \theta - \psi$ , and  $V_{RMS} = \frac{V_M}{\sqrt{2}}$  and  $I_{RMS} = \frac{I_M}{\sqrt{2}}$  then

$$p(t) = V_M \cos(\omega t + \theta) \times I_M \cos(\omega t + \theta - \phi)$$

$$p(t) = V_{RMS} I_{RMS} (\cos \phi + \cos(2(\omega t + \theta) - \phi))$$

where

$p(t)$  is the instantaneous power,

$v(t)$  is the instantaneous voltage signal,

$i(t)$  is the instantaneous current signal,

$V_M$  is the amplitude of the voltage signal,

$I_M$  is the amplitude of the current signal,

$\theta$  is the phase angle of the voltage signal and

$\psi$  is the phase angle of the current signal.

The instantaneous power is integrated in the active energy registers. Over time this removes the double mains frequency component  $\cos(2(\omega t + \theta) - \phi)$  to provide the average power information

$$P = \frac{1}{T} \int_0^T p(t) dt$$

$$P = V_{RMS} I_{RMS} \cos \phi$$

where

$P$  is the average power and

$\cos \phi$  is the power factor.

Reactive power is calculated by applying a 90 degree phase shift to the voltage signal before multiplication:

$$q(t) = v(t - T/4) \times i(t)$$

$$q(t) = V_M \cos(\omega t + \theta - \pi/2) \times I_M \cos(\omega t + \psi)$$

$$q(t) = V_M \sin(\omega t + \theta) \times I_M \cos(\omega t + \theta - \phi)$$

$$q(t) = V_{RMS} I_{RMS} (\sin \phi + \sin(2(\omega t + \theta) - \phi))$$

The instantaneous reactive power is integrated in the reactive energy registers. Over time this removes the double mains frequency component  $\sin(2(\omega t + \theta) - \phi)$  to provide the average reactive power information

$$Q = \frac{1}{T} \int_0^T q(t) dt$$

$$Q = V_{RMS} I_{RMS} \sin \phi$$

where

$Q$  is the average reactive power.



### Linearity

The SA9903B is a CMOS integrated circuit, which performs power/energy calculations across a dynamic range of 500:1 to an accuracy that exceeds the IEC62053.

### Analog Inputs

The input circuitry of the current and voltage sensor inputs is illustrated in Figure 6. These inputs are protected against electrostatic discharge through clamping diodes. The feedback loops from the outputs of the amplifiers  $A_I$  and  $A_V$  generate virtual short circuits between IIP and IIN as well as IVP and AGND. The current sense inputs (IIP and IIN) are identical and balanced. The AD converters convert the signals on the voltage and current sense inputs to a digital format for further processing. All internal offsets are eliminated through the use of various cancellation techniques.

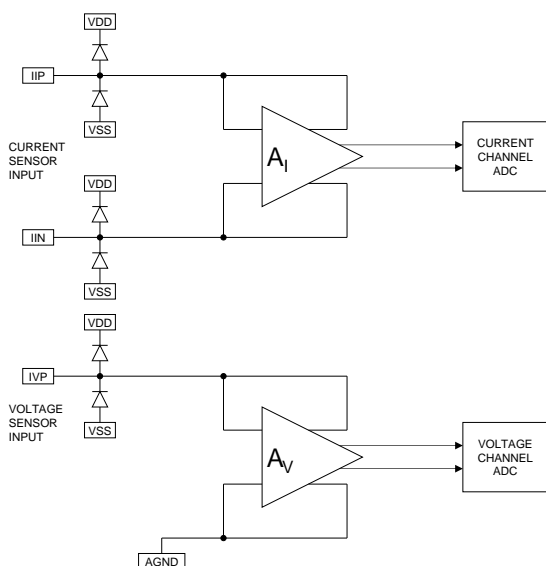

Figure 6: Analog input configuration

### Power-On Reset

The SA9903B has a power-on reset circuitry that activates whenever the voltage between  $V_{DD}$  and  $V_{SS}$  is less than  $3.6V \pm 8\%$ .

### Power Consumption

The power consumption of the SA9903B integrated circuit is less than 25mW.

## INPUT SIGNALS

### Voltage Reference (VREF)

A bias resistor of  $24k\Omega$  sets optimum bias and reference conditions on chip.

### Current Sense Inputs (IIP and IIN)

Figure 7 shows the typical connections for the current sensor input when using a shunt or a current transformer as a current sensing element. At maximum rated mains current ( $I_{MAX}$ ) the resistor values should be selected for an input current of  $16\mu A_{RMS}$ . The current sense inputs saturate at an input current of  $\pm 17.6\mu A_{RMS}$  ( $\pm 25\mu A_{PEAK}$ ), so this allows about 10% headroom until saturation occurs.

The resistor RSH is the shunt resistor. The voltage drop across RSH at maximum rated mains current ( $I_{MAX}$ ) should not be less than  $5mV_{RMS}$  and not exceed  $100mV_{RMS}$ .

The resistors RA and RB form the current transformers termination resistor. The reference level is connected in the centre of the termination resistor to achieve purely differential input currents. The voltage drop across the termination resistors at maximum rated mains current ( $I_{MAX}$ ) should be in the order of  $100mV_{RMS}$ . The termination resistance should also be significantly smaller than the DC resistance of the current transformers secondary winding.

The resistors R1 to R4 define the current flowing into the device. For best performance the SA9903B requires anti-alias filters on the current sense inputs. These filters are realized by means of the capacitors C1 and C2. The typical cut-off frequency of these filters should be between 10kHz and 20kHz. The optimum input network is achieved by setting the input resistors equal, i.e. setting  $R1 = R2 = R3 = R4 = R_c$ . This sets the equivalent resistance associated with each capacitor to  $R_c/2$ .

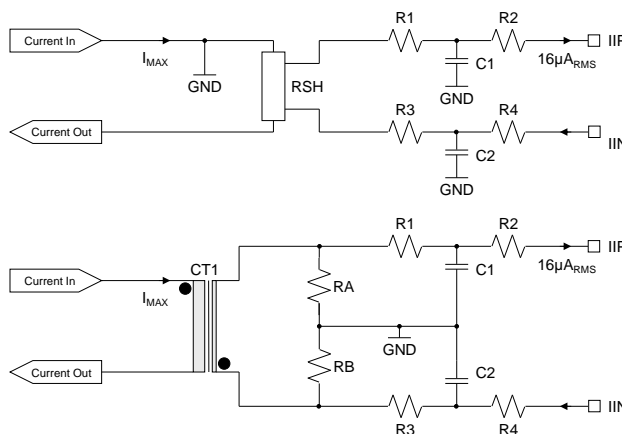

Figure 7: Current sense input configuration

### Voltage Sense Input (IVP)

Figure 8 shows the voltage sense input configuration. The voltage sense input saturates at an input current of  $\pm 17.6\mu\text{A}_{\text{RMS}}$  ( $\pm 25\mu\text{A}_{\text{PEAK}}$ ). The current into the voltage sense input should therefore be set to  $14\mu\text{A}_{\text{RMS}}$  at nominal mains voltage ( $V_{\text{NOM}}$ ) to allow for a mains voltage variation of up to +15% and -50% without saturating the voltage sense input.

For best performance the SA9903B also requires an anti-alias filter on the voltage sense input. Referring to Figure 8, the capacitor C1 is used to both implement the anti-alias filter as well as compensating for any phase shift caused by the current sensing element. The resistor R4 defines the input current into the device. The optimum input network is achieved by setting R4 in the order of  $100\text{k}\Omega$ . If R4 is made too large the capacitor C1 will be very small and the accuracy of the phase compensation could be affected by stray capacitances.

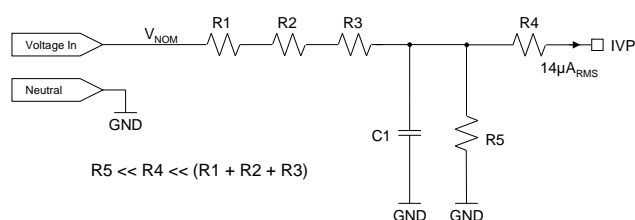

Figure 8: Voltage sense input configuration

### Serial Clock (SCK)

The SCK pin is used to synchronize data interchange between the microcontroller and the SA9903B. The clock signal on this pin is generated by the microcontroller and determines the data transfer rate of the DO and DI pins.

### Serial Data In (DI)

The DI pin is the serial data input pin for the SA9903B. Data will be input at a rate determined by the Serial Clock (SCK). Data will be strobed by the SA9903B on the rising edge of SCK only during an active chip select (CS).

### Chip Select (CS)

The CS input is used to address the SA9903B. A high level on this pin enables the SA9903B to initiate data exchange.

## OUTPUT SIGNALS

### Serial Data Out (DO)

The DO pin is the serial data output pin for the SA9903B. The Serial Clock (SCK) determines the data output rate. Data is only transferred out on the rising edge of SCK during active chip select (CS). This output is tri-state when CS is inactive (low). It is recommended to use an external pull-up or pull-down resistor on DO to ensure its state is always valid.

### Mains Voltage Zero Crossover (FMO)

The FMO output generates a signal, which follows the mains voltage zero crossings, see Figure 9. The microcontroller can use this signal to extract the mains timing or synchronize to the mains voltage.

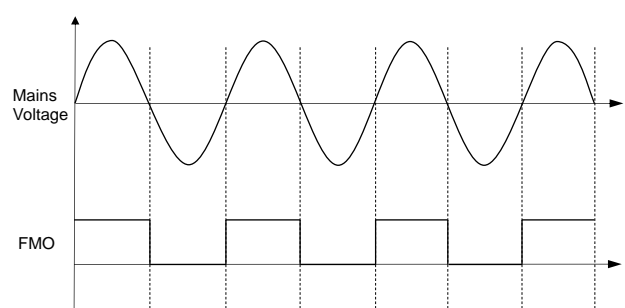

Figure 9: Mains voltage zero crossover

## SPI INTERFACE

### Description

A serial peripheral interface bus (SPI) is a synchronous bus used for data transfers between a microcontroller and the SA9903B. The pins DO (Serial Data Out), DI (Serial Data In), CS (Chip Select), and SCK (Serial Clock) are used in the bus implementation. The SA9903B is the slave device with the microcontroller being the bus master. The CS input initiates and terminates data transfers. A SCK signal (generated by the microcontroller) strobes data between the microcontroller and the SA9903B. The DI and DO pins are the serial data input and output pins for the SA9903B respectively.

### Register Access

Table 1 lists the various register addresses. The SA9903B contains four 24 bit registers representing the active energy, reactive energy the mains voltage and the mains frequency.

Table 1: Register Addressing

ID	Register	Header Bits			Address Bits					
					5	4	3	2	1	0
1	Active energy	1	1	0	X	X	0	0	0	0
2	Reactive energy	1	1	0	X	X	0	0	0	1
3	Voltage	1	1	0	X	X	0	0	1	0
4	Frequency	1	1	0	X	X	1	0	1	1

The header bits 110 (0x06) form the read command and must precede the 6 bit address of the register being accessed. When CS is high, data on the DI pin is clocked into the SA9903B on the rising edge of SCK. Figure 11 shows the data clocked into DI comprising of:

1 1 0 A5 A4 A3 A2 A1 A0

Address locations A5 and A4 are included for compatibility with future developments. Their state is ignored at present but it is best to set them to zero. The 9 bits needed for register addressing can be padded with leading zeros when the

microcontroller requires an 8 bit SPI word length. The following sequence is valid:

0 0 0 0 0 0 1 1 0 A5 A4 A3 A2 A1 A0

Registers may be read individually and in any order. After a register has been read, the contents of the next register will be shifted out on the DO pin with every SCK clock cycle. This allows multiple subsequent registers to be read. Data output on DO will continue until CS is inactive. The DO pin is tri-state when CS is inactive, allowing multiple SPI devices to be connected to the bus. The content of each register consists of 24 bits of data. The most significant bit is shifted out first.

### Data Format

Figure 11 shows the SPI waveforms and Figure 10 and Table 2 the timing information. After the least significant digit of the address has been entered on the rising edge of SCK, the output DO goes low. Each subsequent rising edge transition on the SCK pin will validate the next data bit on the DO pin. For best reliability of the SPI interface it is recommended to change CS and DI together with the falling edge of SCK and strobe DO on the falling edge of SCK as well, as shown in Figure 11.

Table 2: SPI timing information

Parameter	Description	Min	Max
t <sub>1</sub>	SCK rising edge to DO valid	625ns	1.16µs
t <sub>2</sub>	Setup time for DI and CS before rising edge of SCK	20ns	
t <sub>3</sub>	SCK minimum high time	625ns	
t <sub>4</sub>	SCK minimum low time	625ns	
t <sub>5</sub>	Hold time for DI and CS after rising edge of SCK	625ns	

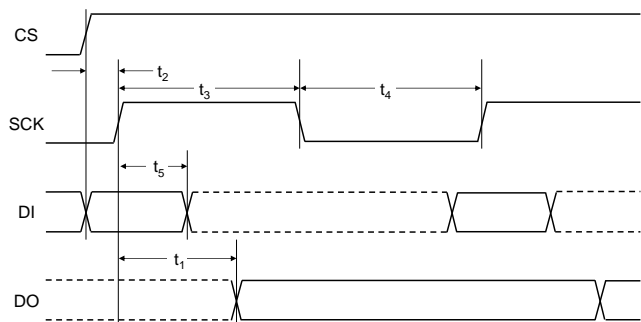

Figure 10: SPI waveform timing diagram

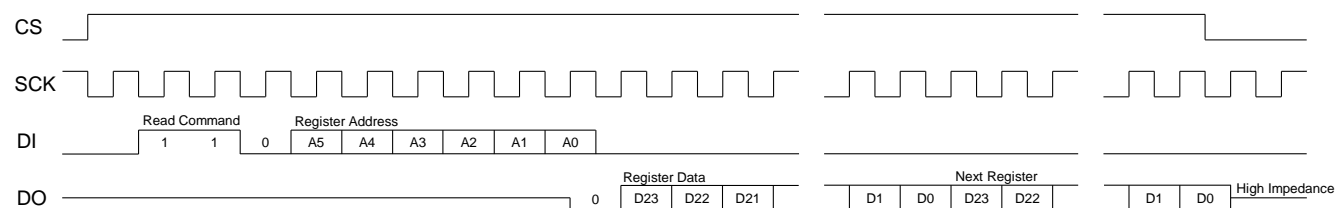

Figure 11: SPI Waveforms

## REGISTER DESCRIPTION

### Active and Reactive Registers

The active and reactive energy measured by the SA9903B is accumulated in 2 distinct registers. These registers are 24 bit up/down counters, that increment or decrement at a rate of 320000 samples per second at rated conditions (nominal mains voltage  $V_{NOM}$  and maximum rated mains current  $I_{MAX}$ ). The register values will increment for positive energy flow and decrement for negative energy flow.

The active and reactive registers are not reset after access, so in order to determine the correct register value the previous value read must be subtracted from the current reading. The data read from the registers represents the active or reactive power integrated over time. The increase or decrease between readings represents the measured energy consumption since the previous register access. At rated conditions, the active and reactive registers will wrap around every 52 seconds. The microcontroller software needs to take this condition into account when calculating the difference between register values. The register difference is always computed correctly if 24 bit arithmetic is used, regardless if a wrap-around has occurred or not. If the controller software uses 32 bit arithmetic, the 24 bit register readings should be sign extended to 32 bits. This ensures that the difference is computed correctly even if a register wrap-around has occurred.

The active and reactive energy measured per register count can be calculated by applying the following formula:

$$\text{Energy per count} = \frac{V_{NOM} \times I_{MAX}}{320000}$$

where

$V_{NOM}$  is the nominal rated mains voltage of meter and  
 $I_{MAX}$  is the maximum rated mains current of meter.  
 The result is watt seconds or var seconds.

The active and reactive power measured by the SA9903B is calculated as follows:

$$\text{Power} = \frac{V_{NOM} \times I_{MAX} \times N}{320000 \times T_{INT}}$$

where

$N$  is the difference in register values between successive register reads and  
 $T_{INT}$  is the time difference between successive register reads.

### Voltage Registers

The voltage register contains the RMS voltage measured by the device. This measurement is a true RMS measurement which is accurate to 1% for a range of 50% to 115% of the rated mains voltage. The RMS mains voltage measured by the SA9903B is calculated as follows:

$$\text{RMS Mains Voltage} = \frac{V_{NOM} \times VREG}{700}$$

where

$VREG$  is the voltage register value.

The value of the voltage register will default to zero when the RMS measurement produces a register value of less than 64. This occurs at a mains voltage of just below 10%  $V_{NOM}$ . The settling time of the RMS measurement algorithm is in the order of 200 mains cycles.

### Frequency register

The frequency register contains the measured mains frequency information. Only bits D0 to D9 are used for the mains frequency calculation result. Bit D23 is a voltage zero crossover bit. It changes state with each rising edge of the mains voltage. Bits D22 to D10 are unused and default to zero.

The mains frequency measured by the SA9903B is calculated as follows:

$$\text{Mains Frequency} = \frac{F_{CRYSTAL}}{FREG \times 256}$$

where

$FREG$  is frequency register value in bits D9 to D0 and  
 $F_{CRYSTAL}$  is the frequency of the external crystal.

## OSCILLATOR

The SA9903B contains a crystal oscillator driver circuit requiring only an external crystal to be connected between OSC1 and OSC2. All other components are integrated on the device. The recommended crystal is a TV colour burst crystal (3.5795MHz).

## TYPICAL APPLICATION

The following description outlines the basic process required to design a typical single phase energy meter using the SA9903B and a shunt resistor. The meter is capable of measuring 220V/40A/50Hz with a precision better than Class 1 on active energy and Class 2 on reactive energy.

The most important external circuits required for the SA9903B are the current input network, the voltage input network as well as the bias resistor. All resistors should be 1% metal film resistors of the same type to minimize temperature effects. Calibration of a microcontroller based meter is typically done in software so the external circuits do not require calibration mechanisms.

### Bias Resistor

A bias resistor of  $R_{10} = 24k\Omega$  sets optimum bias and reference currents on chip.

### Current Input Network

The voltage drop across the shunt resistor at maximum rated current should not be less than  $5mV_{RMS}$  and not exceed  $100mV_{RMS}$ . A  $320\mu\Omega$  shunt is chosen which sets the voltage drop at maximum rated current to  $12.8mV$  and the maximum power dissipation in the shunt to  $0.5W$ . The voltage across the shunt resistor is converted to the required differential input currents through the current input resistors. Anti-alias filters are incorporated on these input resistors to filter any high frequency signal components that could affect the performance of the SA9903B.

The four current input resistors ( $R_1, R_2, R_3, R_4$ ) should be of equal size to optimize the input networks low pass filtering characteristics, so the values can be calculated as follows:

$$R_1 = R_2 = R_3 = R_4 = I_{MAX} \times \frac{R_{SH}}{4 \times 16\mu A} = 200\Omega = R_C$$

For optimum performance the cut-off frequency of the anti-alias filter should be between  $10kHz$  and  $20kHz$ . The equivalent resistance associated with each capacitor is  $R_C/2$  so the capacitor values should be in the order of

$$C_1 = C_2 = \frac{1}{\pi f_{CI} R_C} = \frac{1}{\pi \times 15kHz \times 200\Omega} \approx 100nF = C_C$$

where  $f_{CI}$  is the cut-off frequency of the anti-alias filter of the current input network.

### Voltage Input Network

The voltage sense input requires an input current of  $14\mu A_{RMS}$  at  $V_{NOM}$  ( $220V$ ). The mains voltage is divided by means of a voltage divider to a lower voltage that is converted to the required input current by means of the input resistor. Once again an anti-alias filter is required to remove any high frequency signals that could affect the performance of the SA9903B. A shunt typically has very little phase shift so phase compensation is not required.

The input resistor  $R_8$  sets the current input into the device. This resistor should not be too large else the capacitor for the anti-alias filter will be quite small which could cause inaccurate phase shift due to parasitic capacitances. Therefore  $R_8 = 100k\Omega$  is chosen.  $R_9$  should be significantly smaller than  $R_8$ , but not too small in order to limit the power dissipation of the voltage input network. Hence  $R_9 = 4.3k\Omega$  is chosen. Now let  $R_A = R_{19} + R_{20} + R_{21}$  and

$$R_A = R_9 \times \left( \frac{220V}{1.4V} - 1 \right) \approx 671k\Omega$$

so choose  $R_{19} = R_{20} = R_{21} = 220k\Omega$ .

The cut-off frequency of the anti-alias filter is adjusted so that it is identical to that of the current input network anti-alias filters. This ensures that the phase shift caused by the anti-alias filters is identical on the current and voltage input networks. Therefore

$$\frac{1}{\pi C_C \times R_C} = \frac{1}{2\pi \times R_9 \times C_3}$$

and so set  $C_3 = 2.2nF$ .

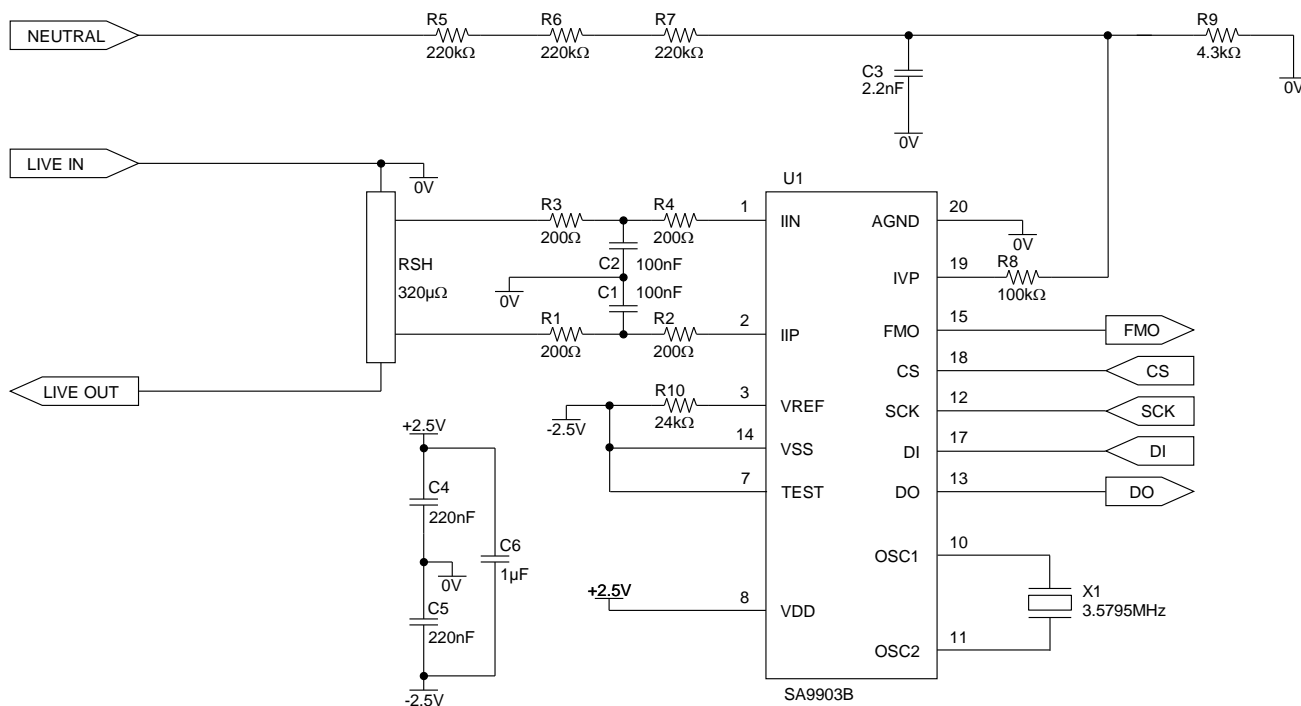

Figure 12: Typical application circuit

Table 3: Component list for typical application

Symbol	Description
U1	Energy metering device, SA9903BSAR
RSH	Shunt Resistor, 40A, 320µΩ
R1, R2 <sup>1</sup> , R3, R4 <sup>1</sup>	Resistor, 200Ω, 1%, metal film
R5, R6, R7	Resistor, 220kΩ, 1%, metal film
R8 <sup>1</sup>	Resistor, 100kΩ, 1%, metal film
R9	Resistor, 4.3kΩ, 1%, metal film

Symbol	Description
R10 <sup>1</sup>	Resistor, 24kΩ, 1%, metal film
X1	Crystal, 3.5795MHz
C1, C2	Capacitor, 100nF, ceramic
C3	Capacitor, 2.2nF, ceramic
C4 <sup>2</sup> , C5 <sup>2</sup>	Capacitor, 220nF, ceramic
C6 <sup>2</sup>	Capacitor, 1µF, ceramic

Note 1: Resistors R2, R4, R8 and R10 must be positioned as close as possible to the respective device pins

Note 2: Capacitors C4, C5 and C6 must be positioned as close as possible to the VDD and VSS power supply pins



### PACKAGE DIMENSIONS

#### SOIC20 Package

Dimensions are shown in inches

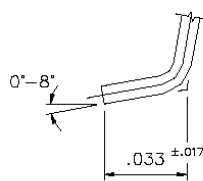
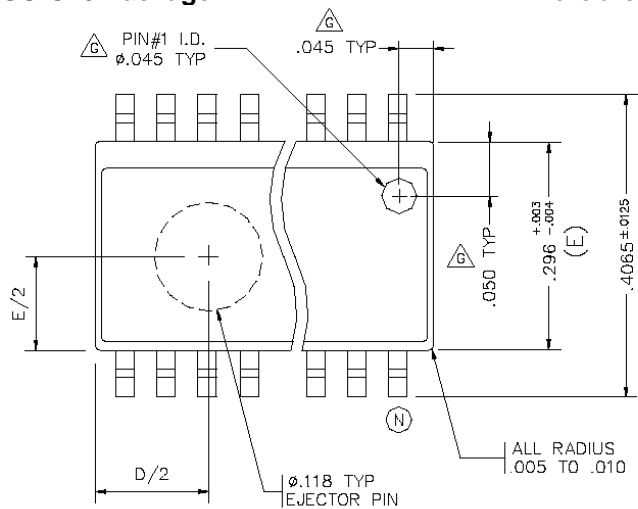

N	D VARIATIONS		
	MIN	NOM	MAX
16	.398	.405	.412
18	.449	.456	.463
20	.496	.503	.510
24	.599	.606	.613
28	.697	.704	.711

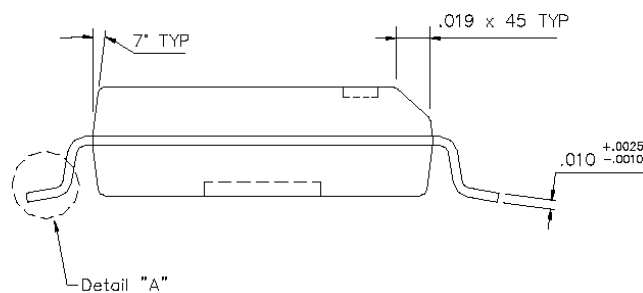
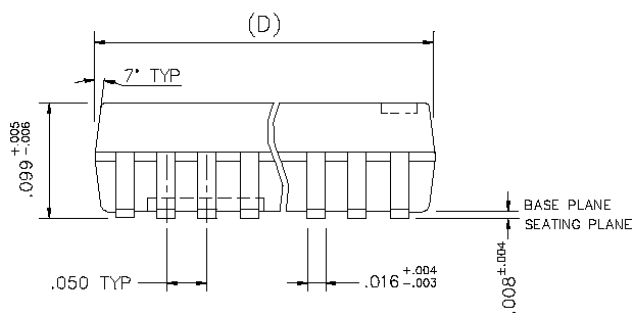



NOTES



## DISCLAIMER

The information contained in this document is confidential and proprietary to Integrated Circuit Design Centre (Pty) Ltd ("ICDC"), a division of South African Micro-Electronic Systems (Pty) Ltd ("SAMES"), and may not be copied or disclosed to a third party, in whole or in part, without the express written consent of ICDC. The information contained herein is current as of the date of publication; however, delivery of this document shall not under any circumstances create any implication that the information contained herein is correct as of any time subsequent to such date. ICDC does not undertake to inform any recipient of this document of any changes in the information contained herein, and ICDC expressly reserves the right to make changes in such information, without notification, even if such changes would render information contained herein inaccurate or incomplete. ICDC makes no representation or warranty that any circuit designed by reference to the information contained herein, will function without errors and as intended by the designer.

Any sales or technical questions may be sent to our support e-mail address:  
**support@sames.co.za**

For the latest updates on datasheets, please visit our web site:  
**<http://www.sames.co.za>**

**INTEGRATED CIRCUIT DESIGN CENTRE (PTY) LTD**  
a division of  
**SOUTH AFRICAN MICRO-ELECTRONIC SYSTEMS (PTY) LTD**

**Tel:** 012 333 6021  
**Tel Int:** 00 27 12 333 6021  
**Fax:** 012 333 6393  
**Fax Int:** 00 27 12 333 6393

**PO BOX 15888**  
**LYNN EAST 0039**  
**REPUBLIC OF SOUTH AFRICA**

**UNIT 4, PERSEQUOR CLOSE**  
**49 DE HAVILLAND CRESCENT**  
**PERSEQUOR TECHNOPARK**  
**LYNNWOOD, PRETORIA**  
**REPUBLIC OF SOUTH AFRICA**