

# SAMES KEY RING TAG



## SA7110DKEY

**sames**

### SAMES KEY RING TAG

The SAMES key ring tag provides the secure and convenient link for access control, customer loyalty, personnel identification, etc. It includes the SAMES SA7110 IC and antenna circuit and has been packaged to withstand rough handling associated with key ring use.

The SAMES key ring tag is available as a read only version with a unique factory programmed identification code.

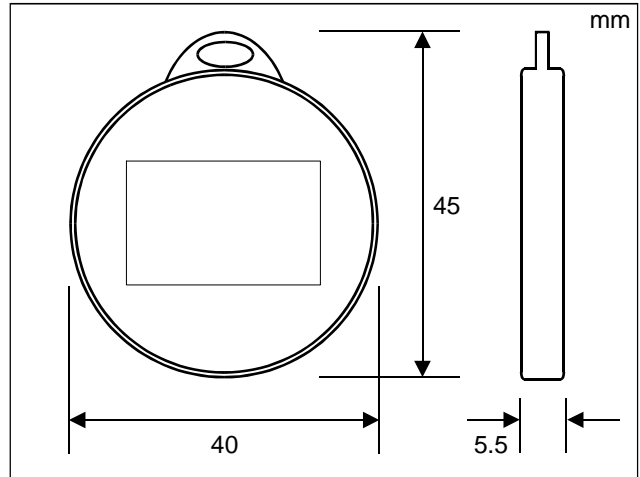

### GENERAL SPECIFICATION

Function	Passive read-only radio frequency identification tag
Memory size	64 bit Read Only Memory
Serialization	40 bit serial number
Typical operating frequency	125 kHz
Modulation / Encoding	Amplitude Shift Keying (ASK) / Manchester
Read Speed	1953 bits/second (32.8ms read time typically)
Power source	Powered from the reader signal
Operating Temperature	-40 to +70°C
Storage Temperature:	-40 to + 70°C
Case Material	Plastic ABS
Protection Class	TBA
Colour	Black

### MEMORY ARRAY

The SA7110 IC used in the key ring tag contains 64 bits divided in to five groups of information. 9 bits are used for the header, 10 row parity bits (P0-P9), 4 column parity bits (PC0-PC3), 40 data bits (D00-D93) and 1 stop bit set to logic 0.

The header is composed of the 9 bits which are all programmed to "1". The header is followed by 10 groups of 4 data bits and 1 row parity bit. The 10 groups of 4 data bits allow for 100 billion combinations. The last group consists of 4 column parity bits with 1 stop bit which is programmed to "0".

Bits D00 to D03 and bits D10 to D13 are customer specific identification.

The 64 bits are outputted serially in order to control the modulator. The output sequence is repeated continuously as long as the tag is in the reader RF field.

1	1	1	1	1	1	1	1	1	9 header bits		
8 version bits or customer ID		D00	D01	D02	D03	P0					
		D10	D11	D12	D13	P1					
32 data bits		D20 D21 D22 D23				P2					
		D30 D31 D32 D33				P3					
		D40 D41 D42 D43				P4					
		D50 D51 D52 D53				P5					
		D60 D61 D62 D63				P6					
		D70 D71 D72 D73				P7					
		D80 D81 D82 D83				P8					
		D90 D91 D92 D93				P9					
		4 column parity bits		PC0	PC1	PC2	PC3	S0		10 line parity bits	Stop bit

**DISCLAIMER:**

The information contained in this document is confidential and proprietary to South African Micro-Electronic Systems (Pty) Ltd ("SAMES") and may not be copied or disclosed to a third party, in whole or in part, without the express written consent of SAMES. The information contained herein is current as of the date of publication; however, delivery of this document shall not under any circumstances create any implication that the information contained herein is correct as of any time subsequent to such date. SAMES does not undertake to inform any recipient of this document of any changes in the information contained herein, and SAMES expressly reserves the right to make changes in such information, without notification, even if such changes would render information contained herein inaccurate or incomplete. SAMES makes no representation or warranty that any circuit designed by reference to the information contained herein, will function without errors and as intended by the designer.

Any sales or technical questions may be posted to our e-mail address below:  
**[id\\_security@sames.co.za](mailto:id_security@sames.co.za)**

For the latest updates on datasheets, please visit our web site:  
**<http://www.sames.co.za>**

**SOUTH AFRICAN MICRO-ELECTRONIC  
SYSTEMS (PTY) LTD**

**Tel:** (012) 333-6021  
**Tel: Int** +27 12 333-6021  
**Fax:** (012) 333-8071  
**Fax: Int** +27 12 333-8071

**P O BOX 15888  
33 ELAND STREET  
LYNN EAST 0039  
REPUBLIC OF SOUTH AFRICA**

**33 ELAND STREET  
KOEDOESPOORT INDUSTRIAL AREA  
PRETORIA  
REPUBLIC OF SOUTH AFRICA**